

Sketching ve výuce předmětu VT4

Figura a prostor

Autorský tým:

Ing. arch. BcA. Jiří Kárník, doc. Ing. arch. akad. mal. Ivan Vosecký, MgA. Mgr. Radek Macke,
Radka Formánková

Prezentace projektu

- 1. Požadavek ze strany pedagogů na dovednost skicování**
- 2. Sketching:** definice, co to je a co to není? Nový přístup ve výuce
- 3. První zkušenosti.** Pátečními workshopy skicování
- 4. Etablování jednotlivých levelů sketchingu** (1.základní, 2.A+U, 3.Krajinářská tvorba, 4.Design)
- 5. Zavádění do výuky, v současnosti VT4.** Překrytí do VT5. Zkušenosti s dřívější VT6 (digitální skicování)
- 6. Jednotlivé fáze ve výuce sketchingu:**
 - I. elementární dovednosti
 - II. konstrukce prostoru v závislosti na horizontu
 - III. doplňování reality (stafáž, zeleň, figury + další doplňky)

7. I.fáze ve sketchingu: Elementární dovednosti: **čára** 1.technická 2.dynamická, **plocha** 1.technická 2.kreslířská.

1

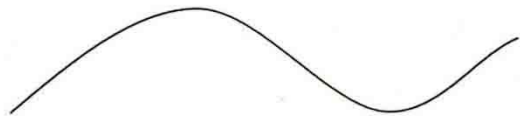

2

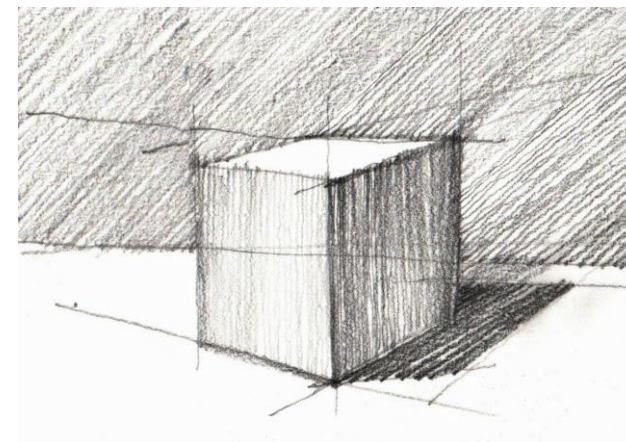
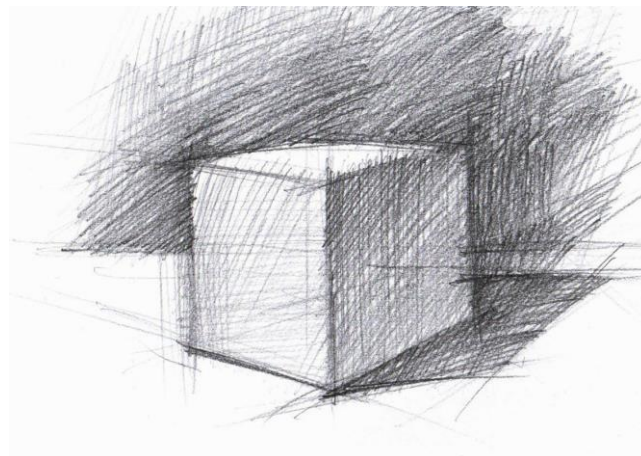
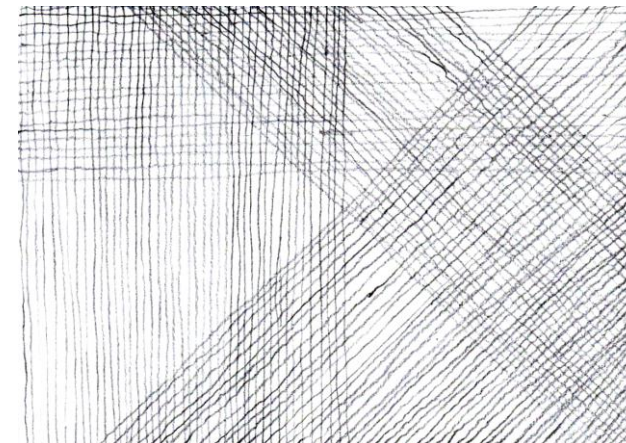
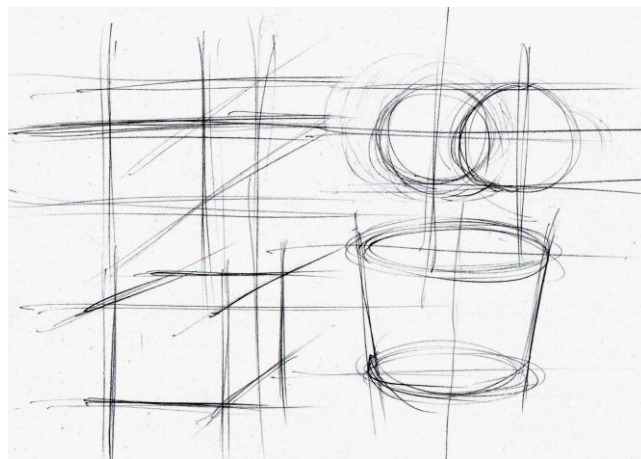
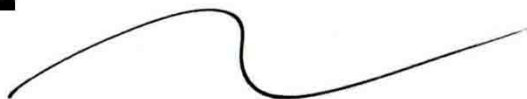

8. II. Fáze: zadávání prostoru průčelně: 1.horizont a hlavní bod

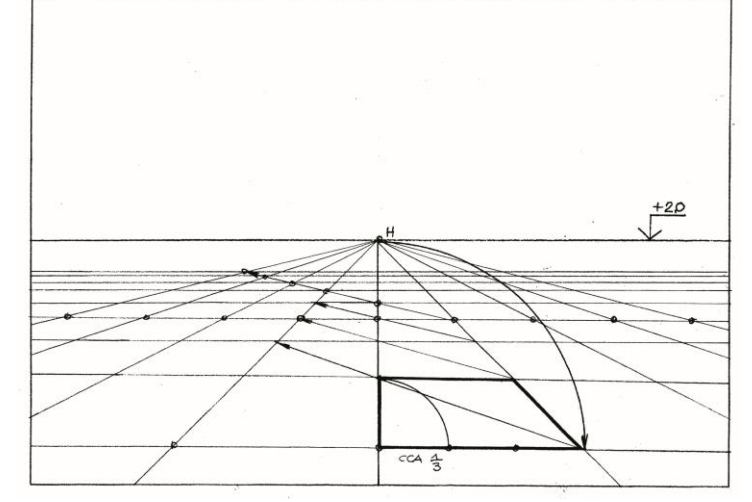
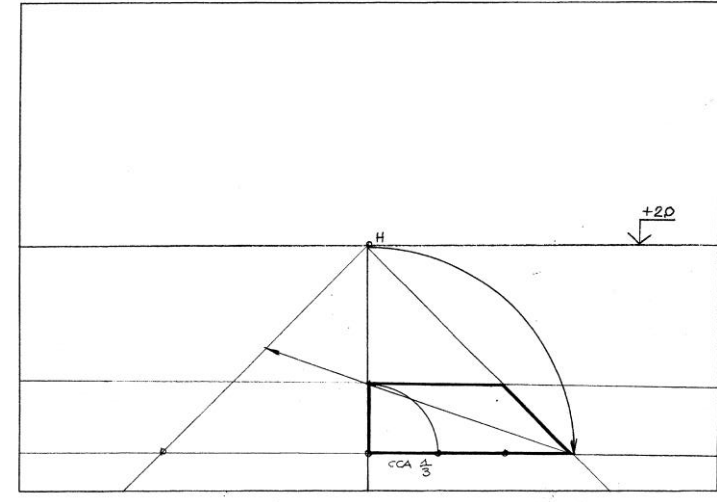
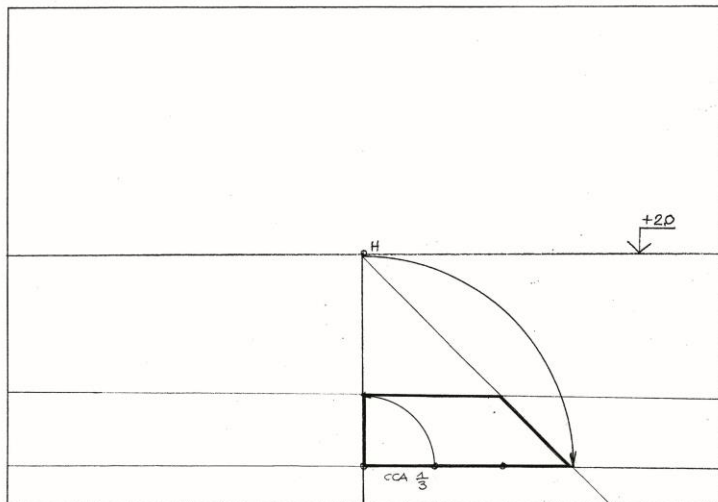
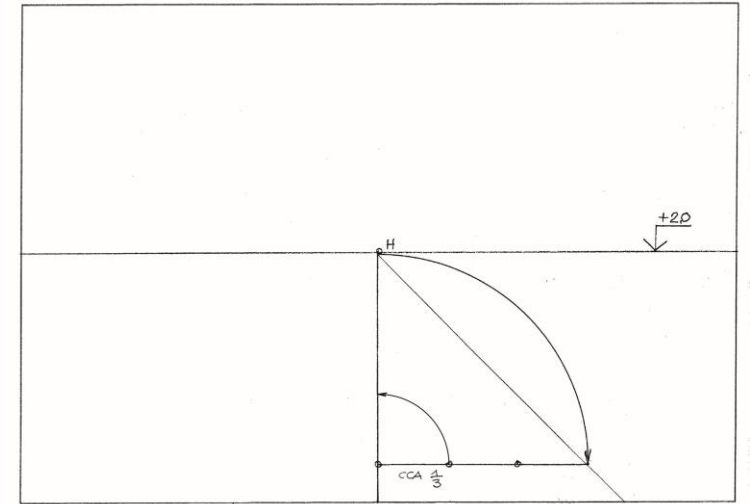
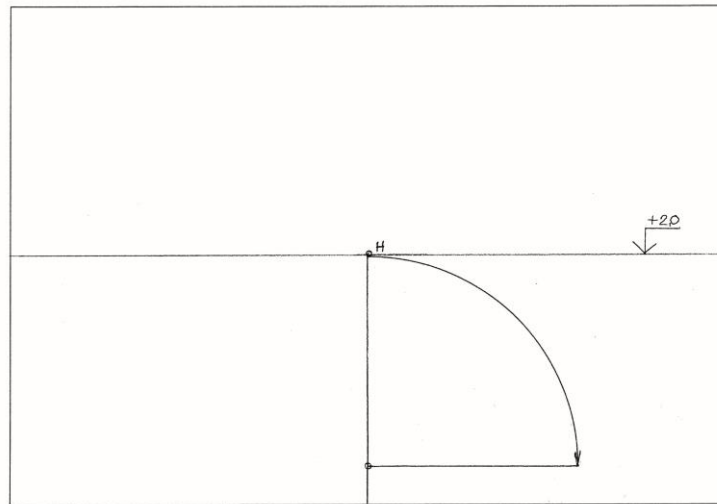
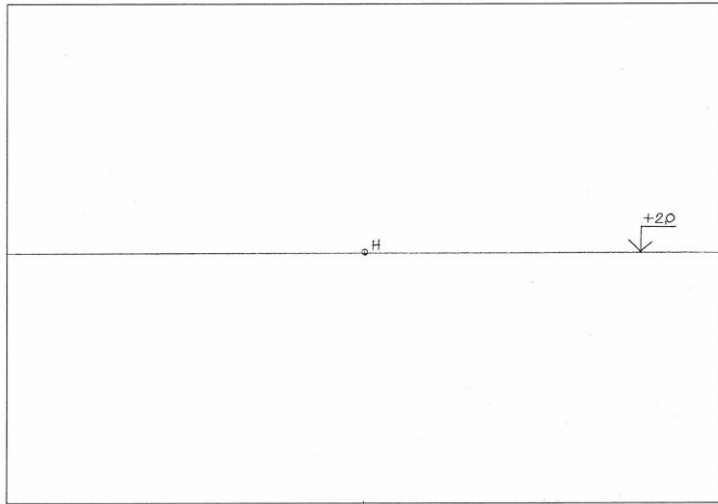

8. II. fáze: zadávání prostoru průčelně: 1.horizont a hlavní bod Ukázka cvičení: Ulička

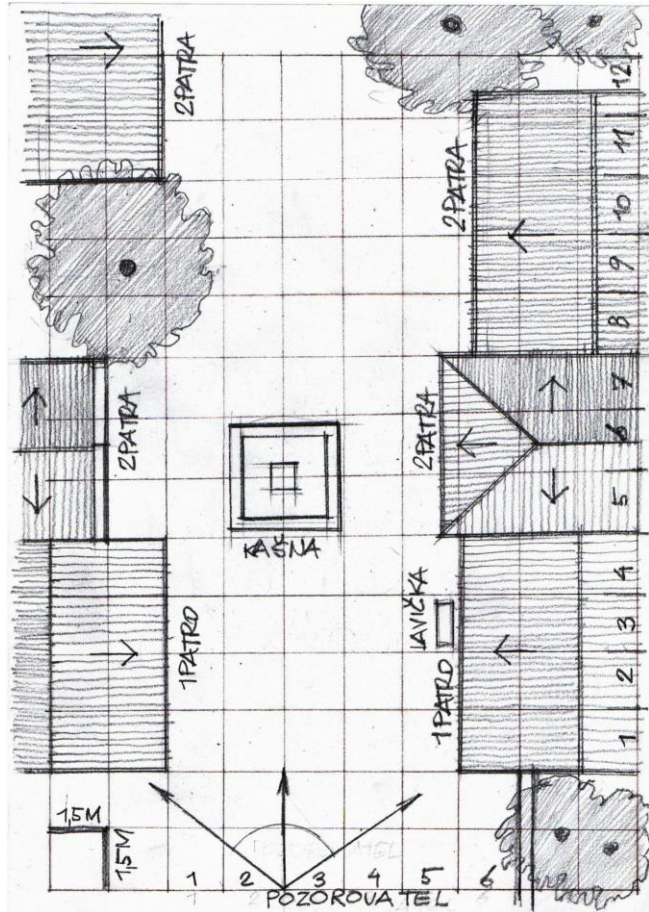

8. II. fáze: Zadávání prostoru průčelně: prostorové zadání krychlí + ukázka řešení náměstí

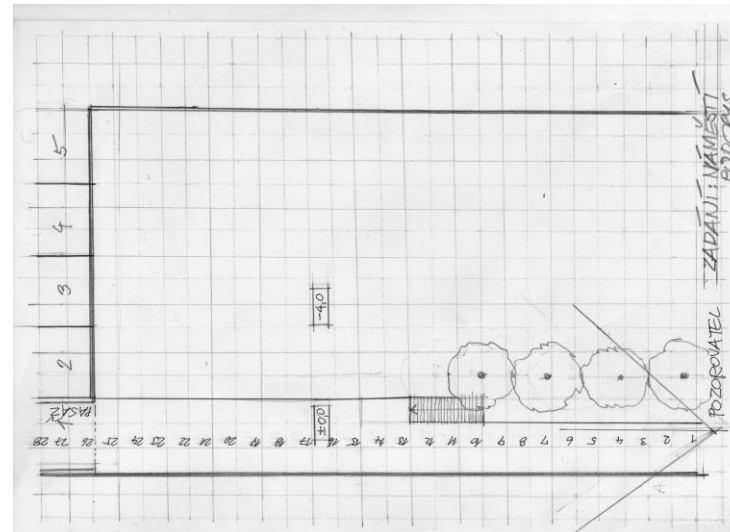
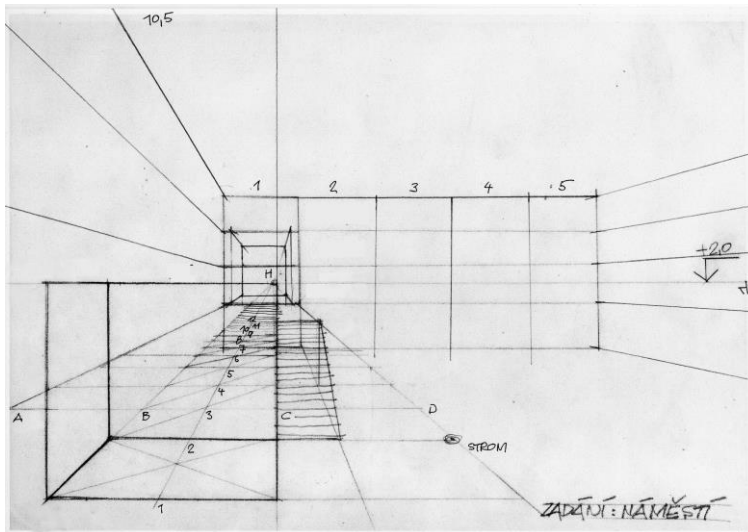
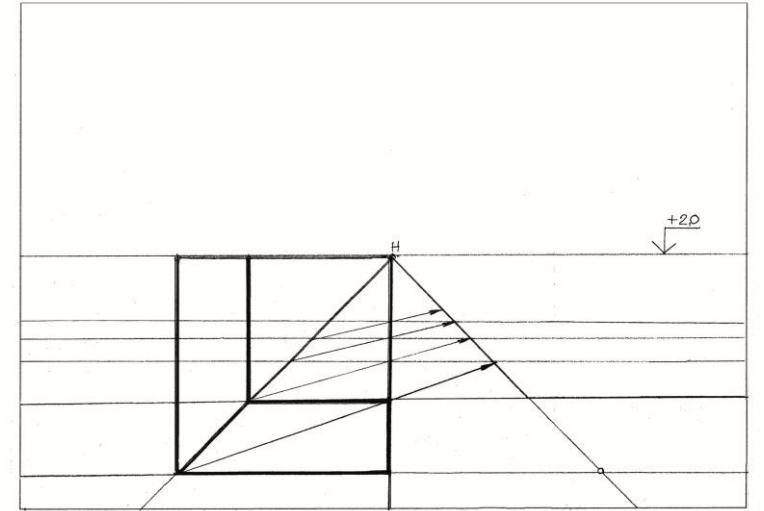
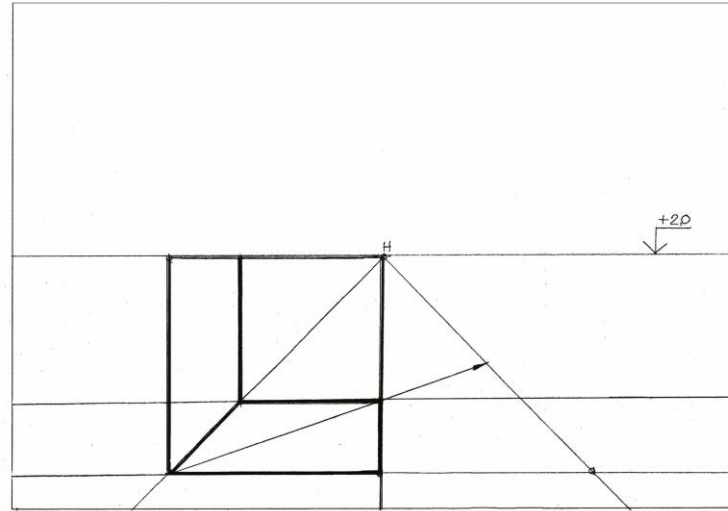
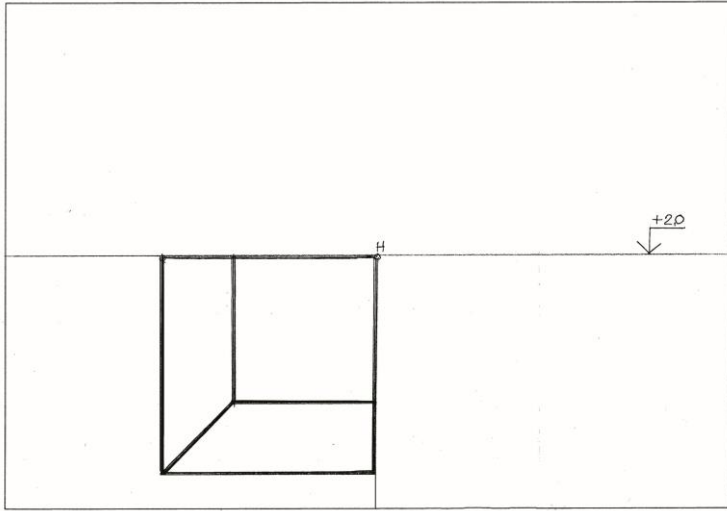

9. II. fáze: Zadávání prostoru pro dva úběžníky

1. horizont a dva úběžníky

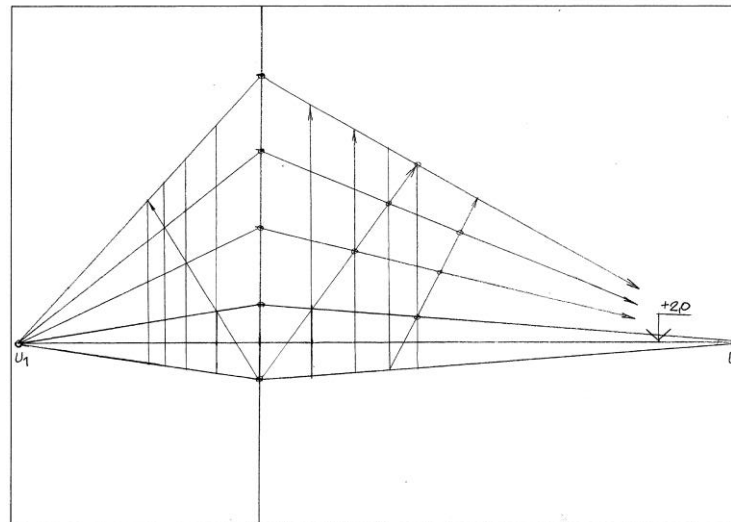
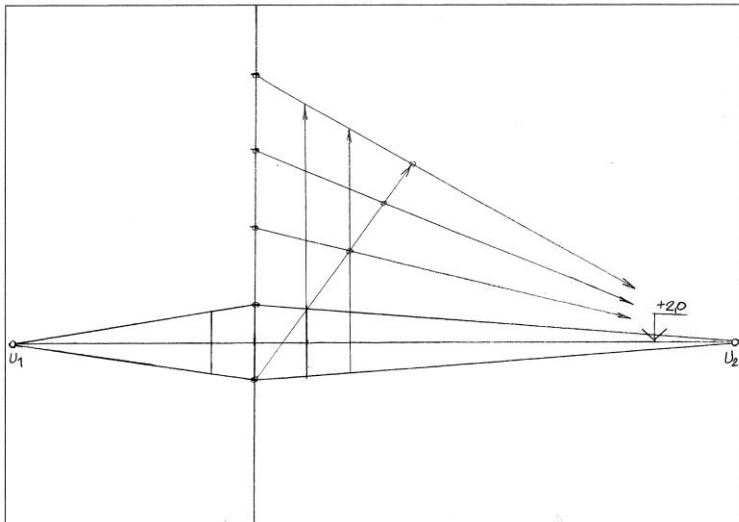
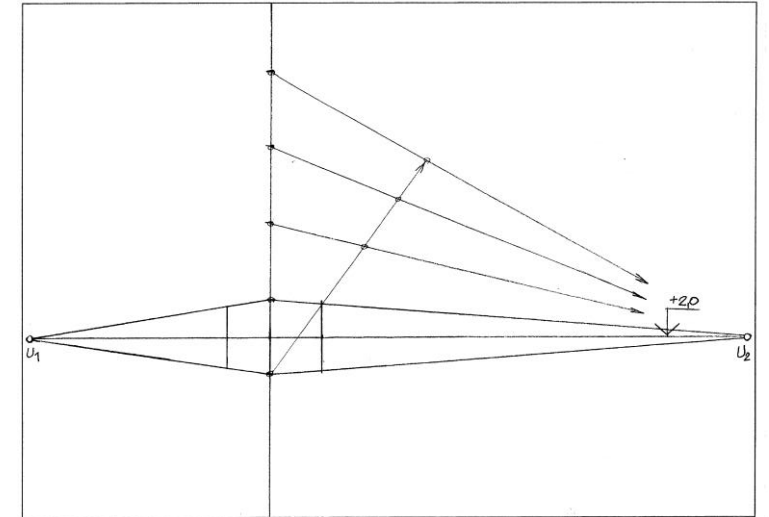
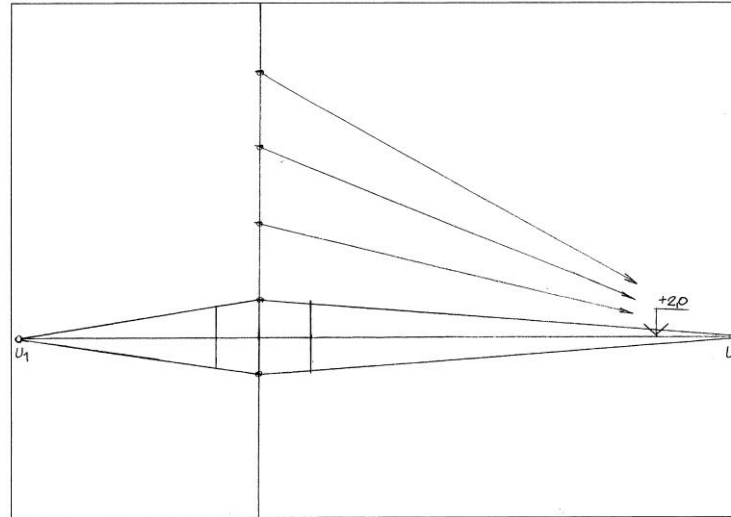
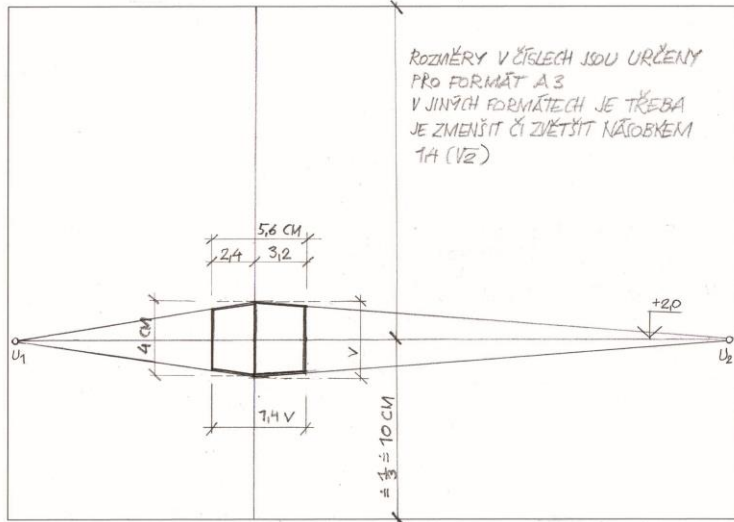

9. II. fáze: Zadávání prostoru pro dva úběžníky Ukázka cvičení: Obchodní ulice

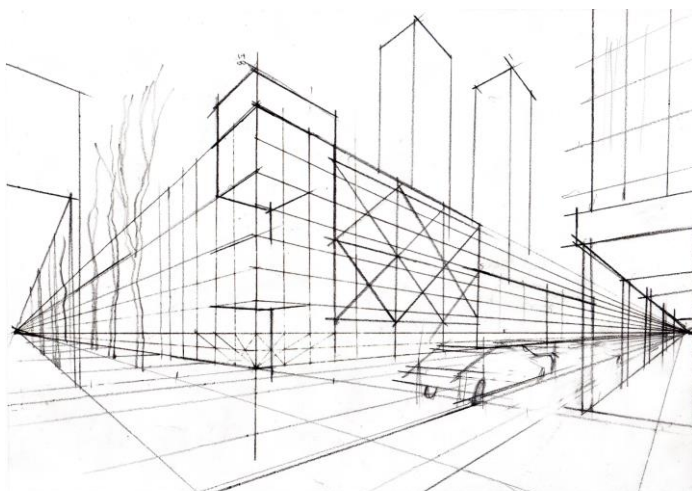
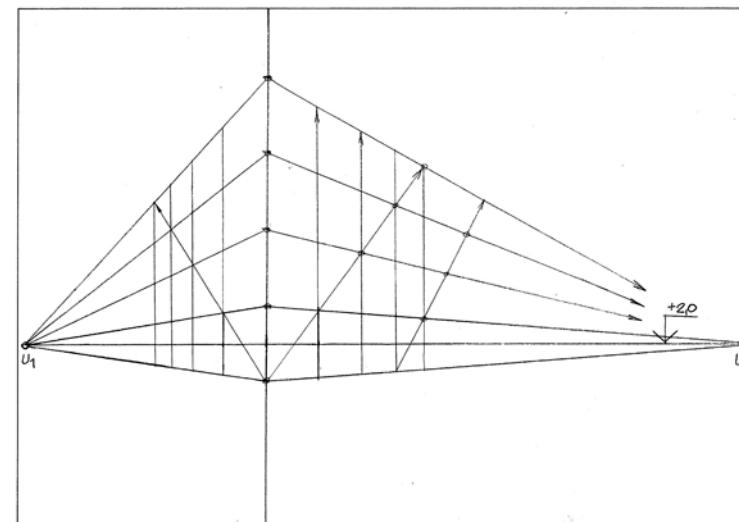
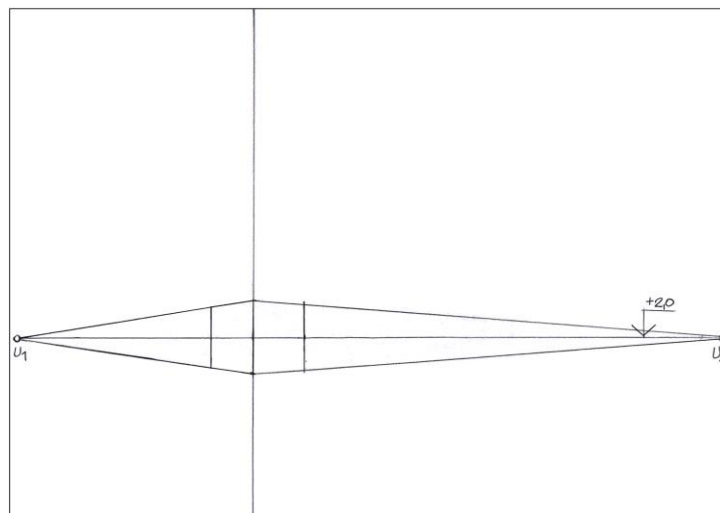
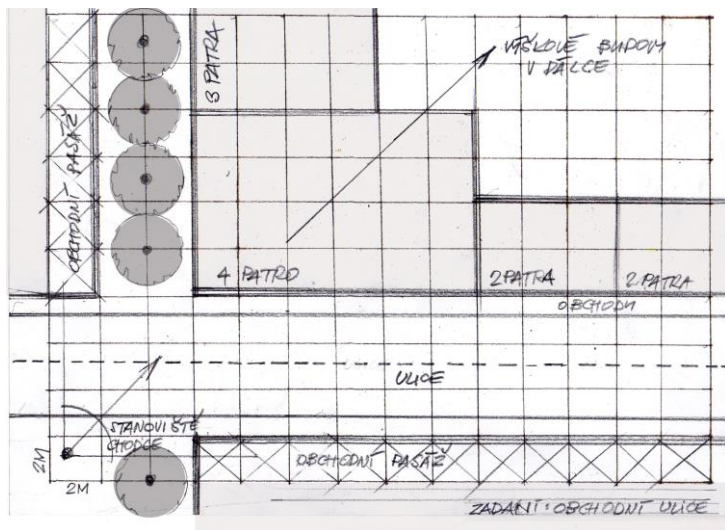

9. II.fáze: Zadávání prostoru pro dva úběžníky čtvercem v perspektivě

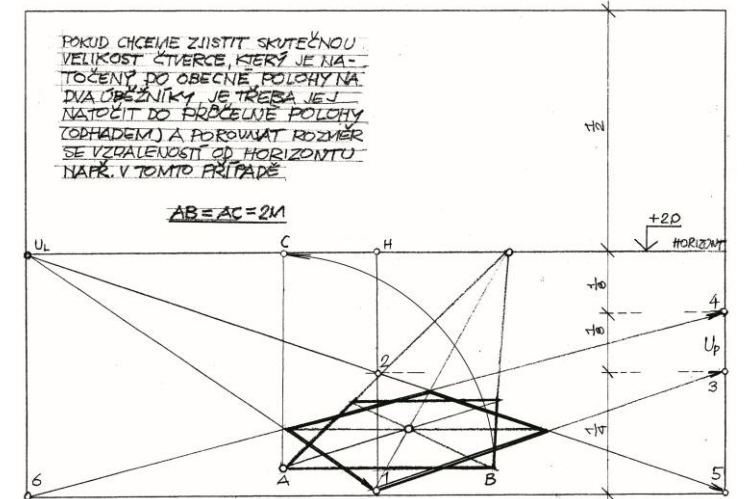
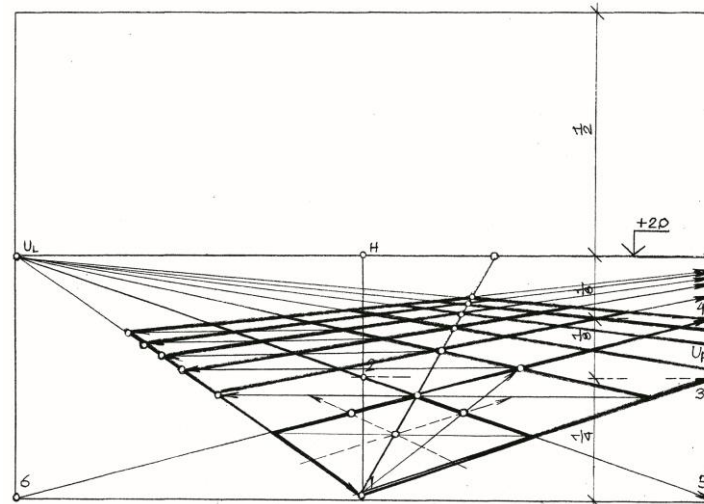
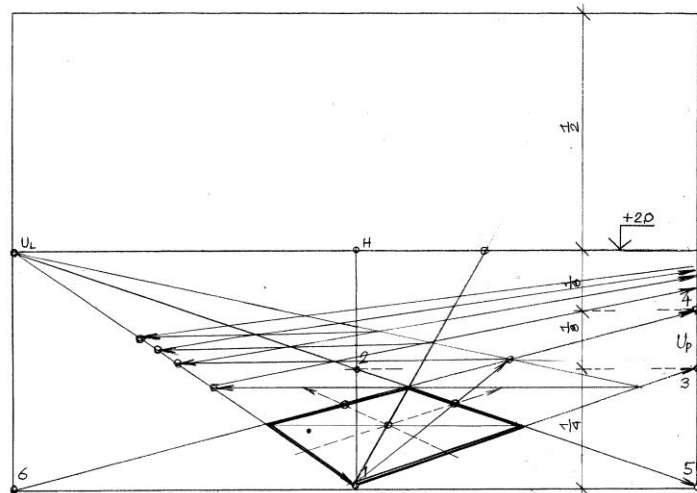
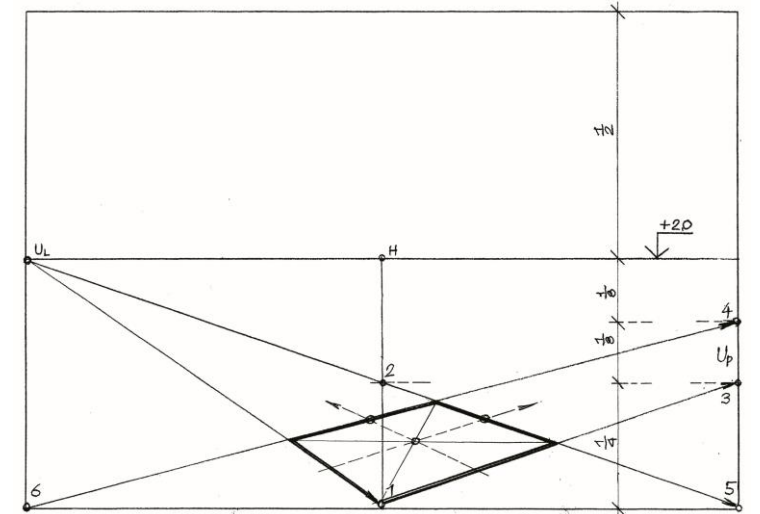
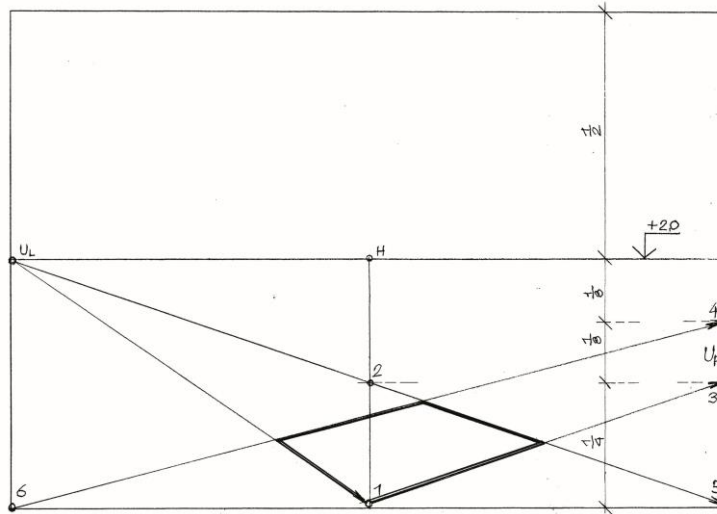
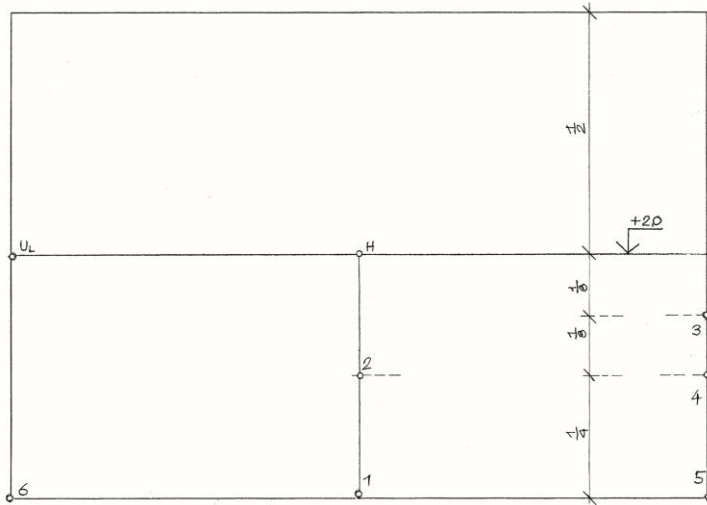

9. II. fáze: Zadávání prostoru pro dva úběžníky Ukázka cvičení:

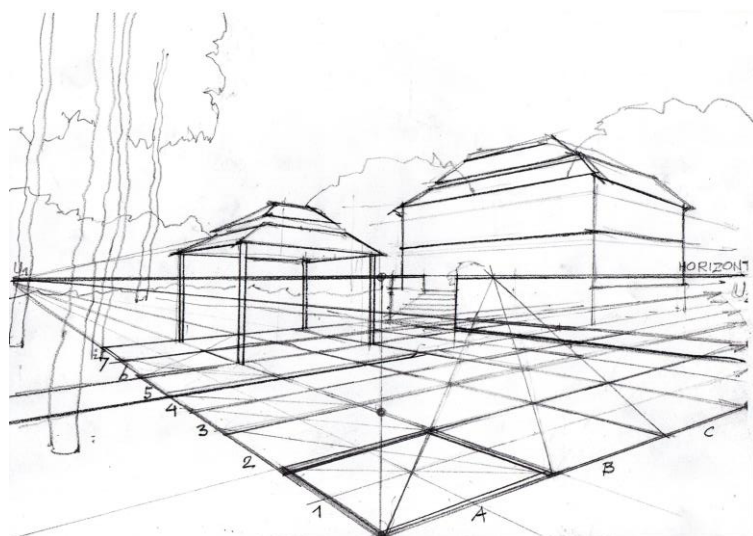
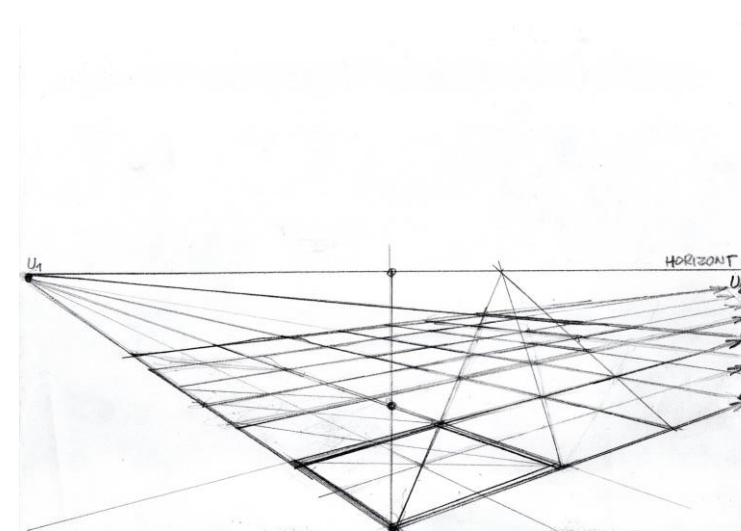
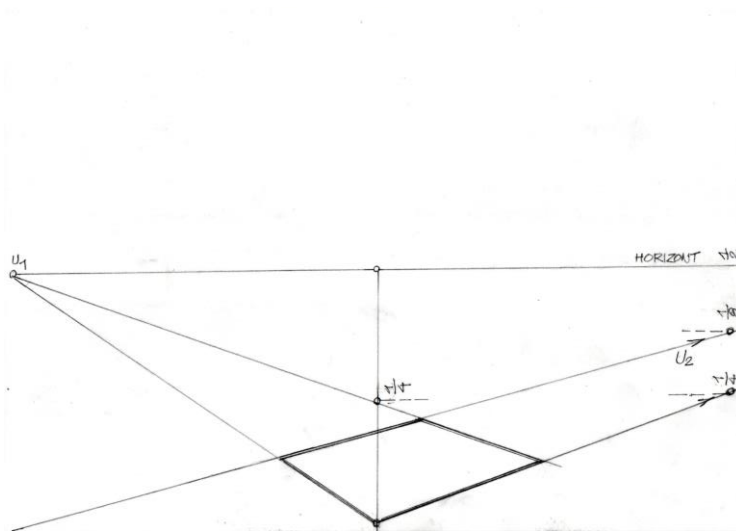
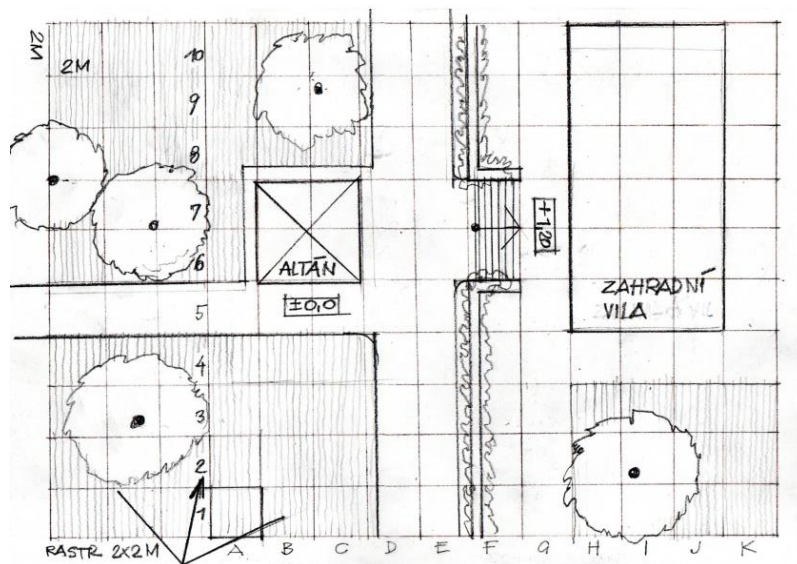

9. II. fáze: Zadávání prostoru pro dva úběžníky čtvercem v půdorysu: vynesení do prostoru průsečnou metodou
 Ukázka cvičení analogická s přecházející úlohou (altán a moderní vila v zahradě)

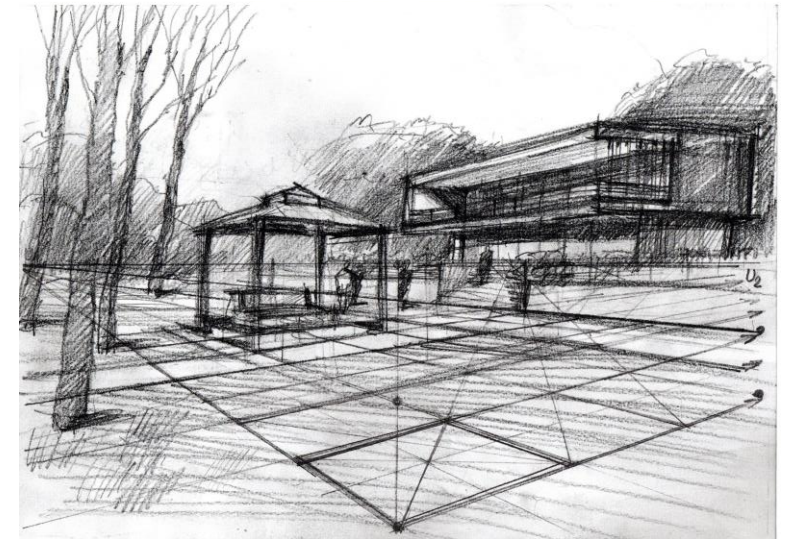
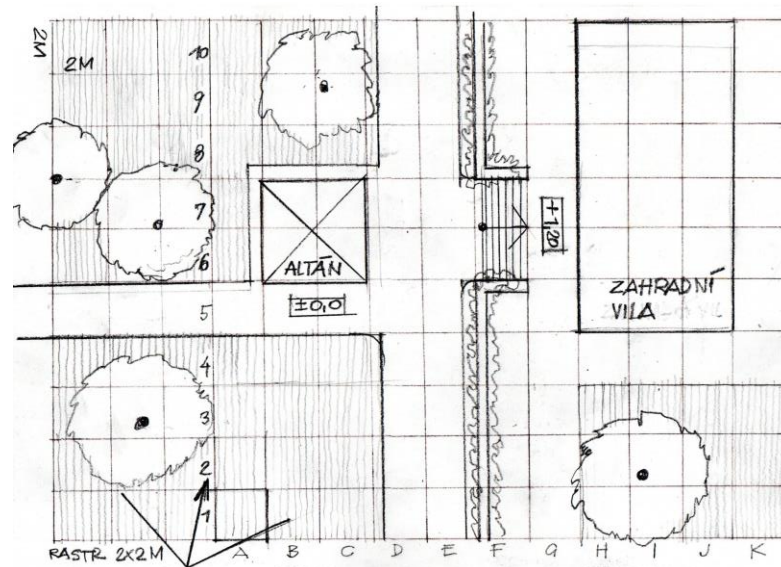
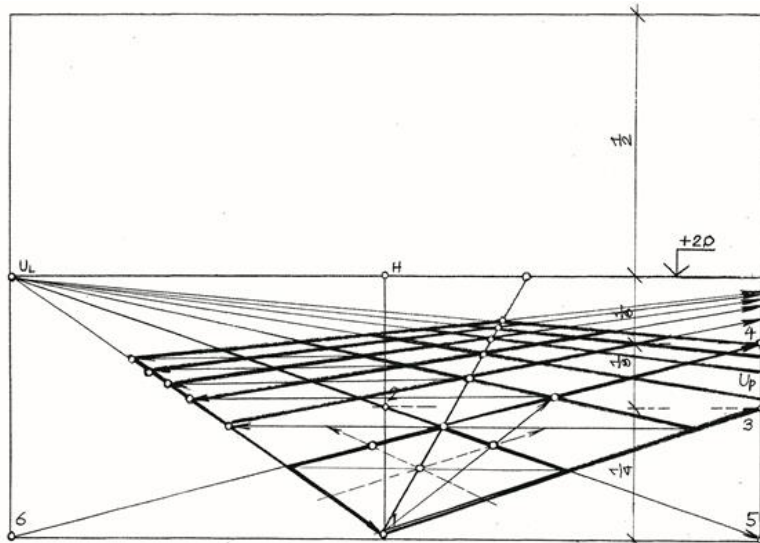
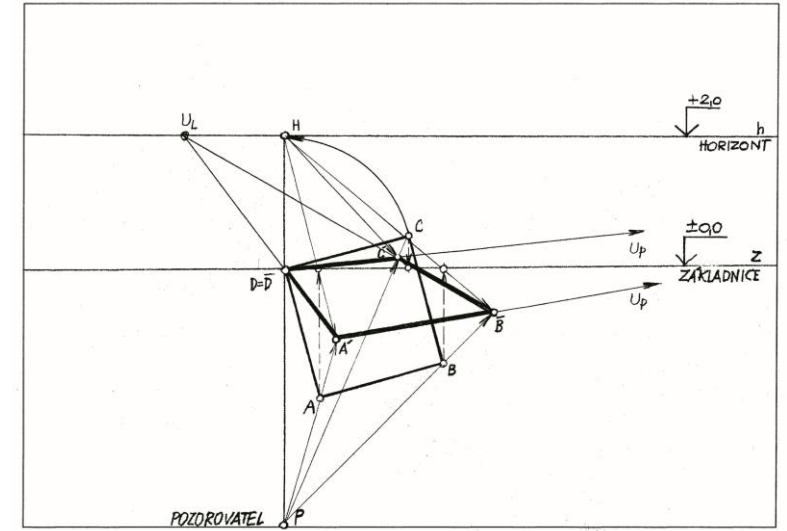
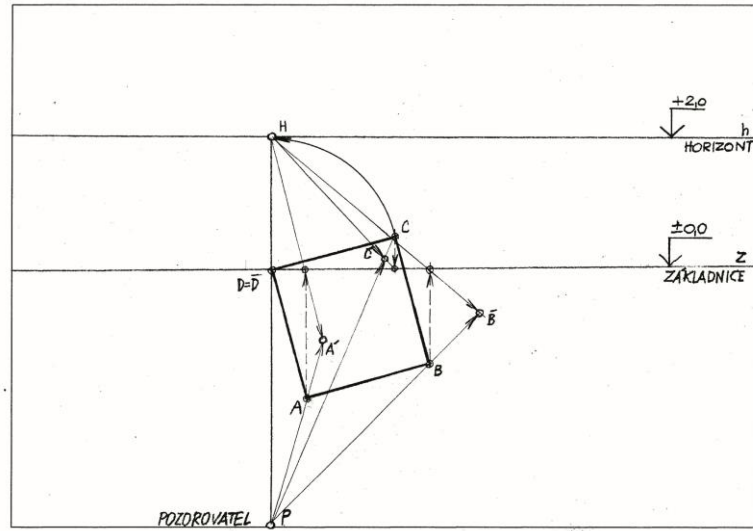
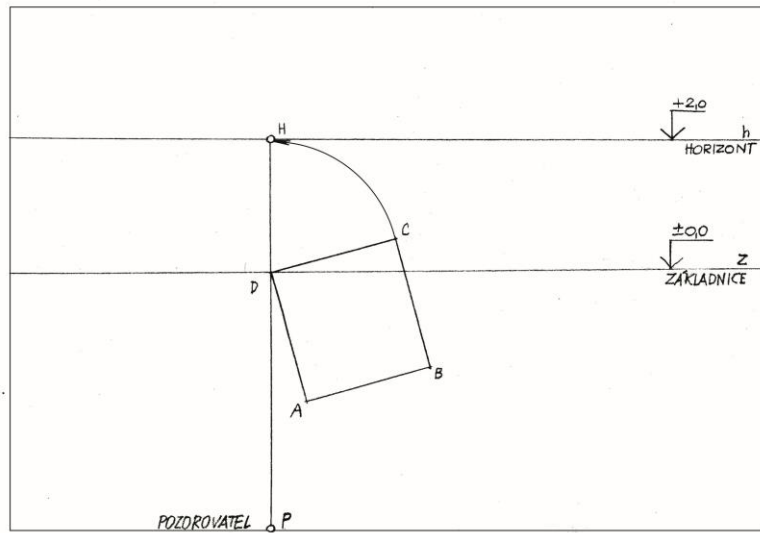

10. III.fáze: Zeleň (manuál): listnatá, jehličnatá, tráva

MĚŘÍTKO LIDSKÉ POSTAVY A STROMO



6-12M



STROMY

2-4M

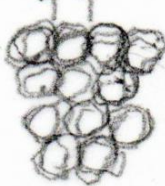

1-1,5



KERÉ

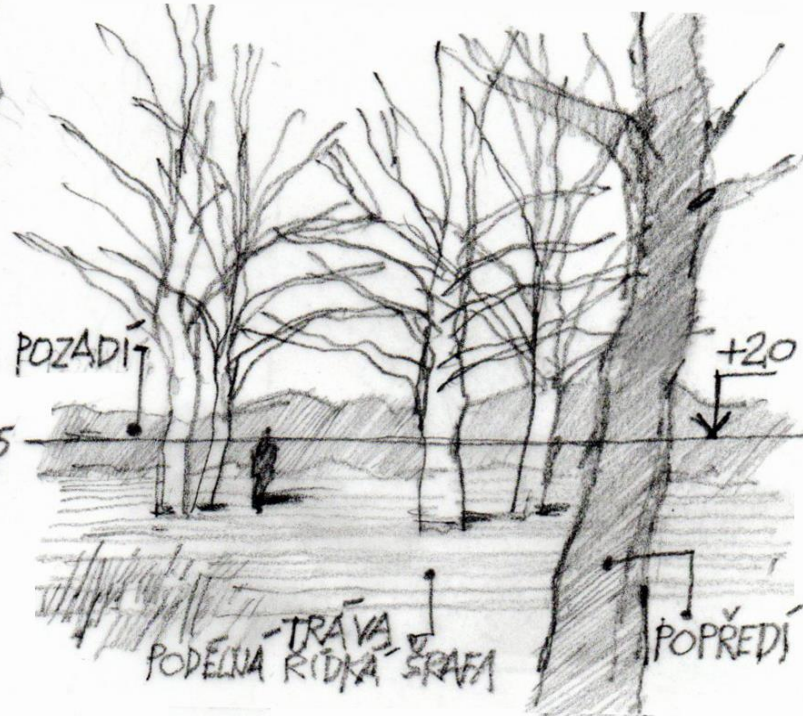

11. III.fáze: Figury: správné umístění, správná velikost, konstrukce figury jako měřítko prostoru (manuál) kontrapost jako přirozenost figury (manuál)

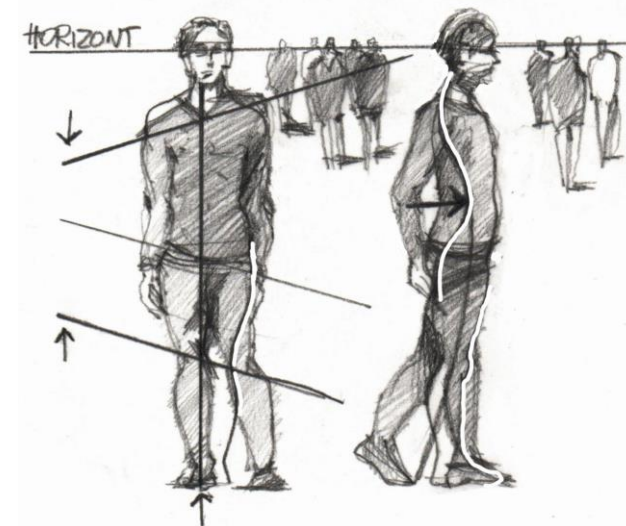
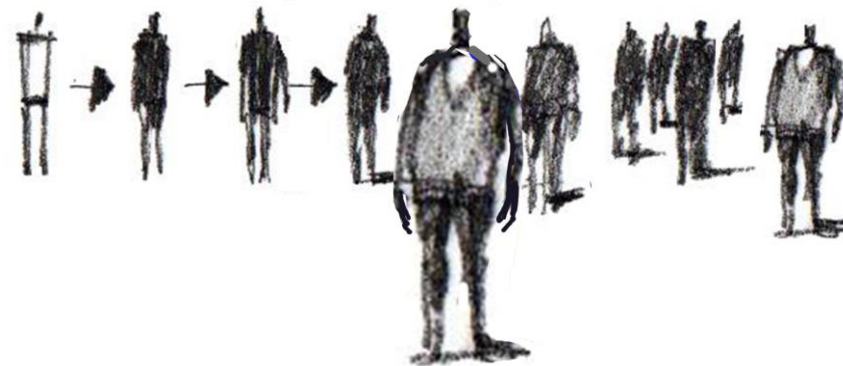
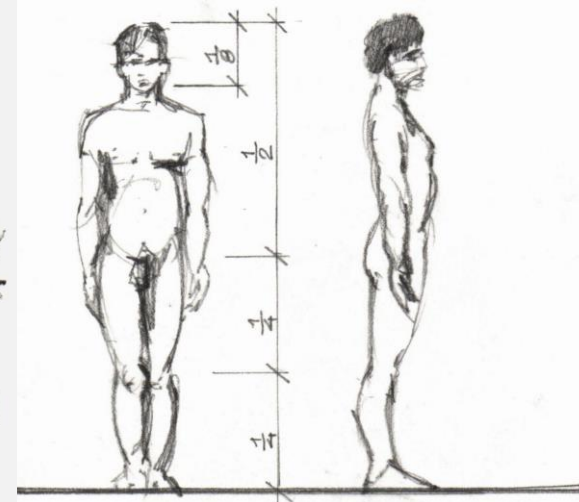
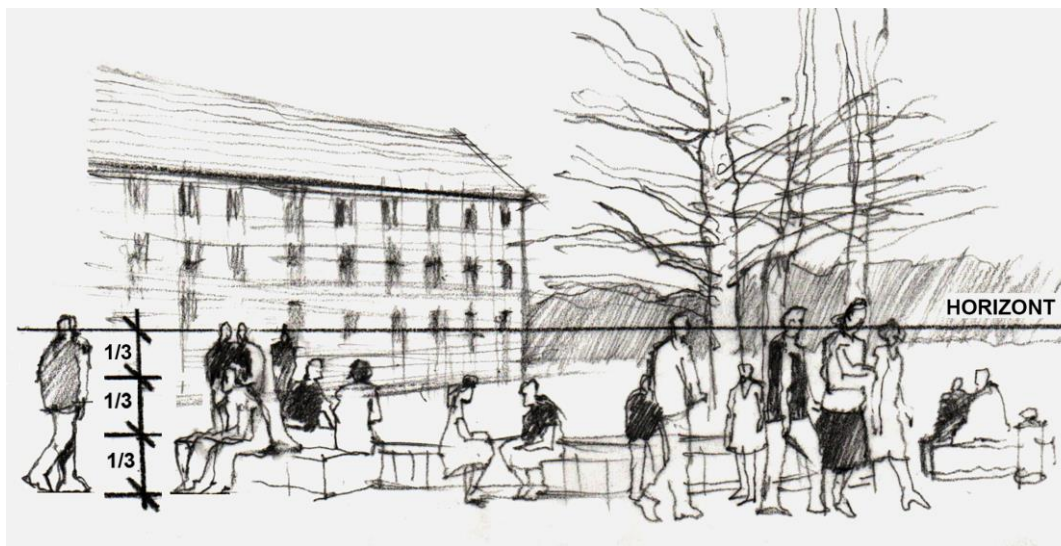
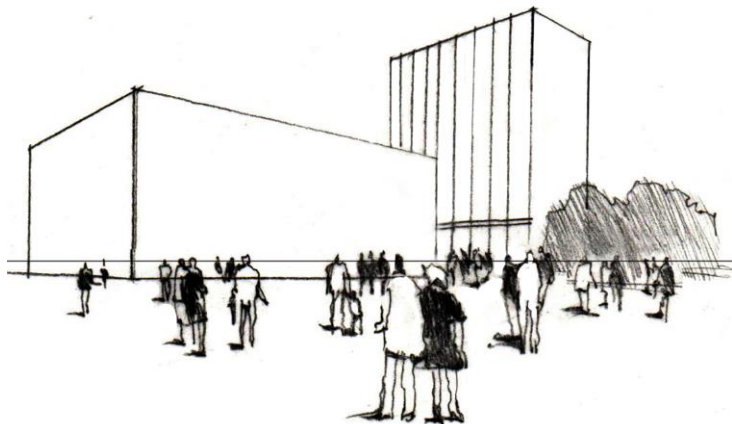

11. III.fáze: Figury: správné umístění, správná velikost, konstrukce figury jako měřítko prostoru (manuál)

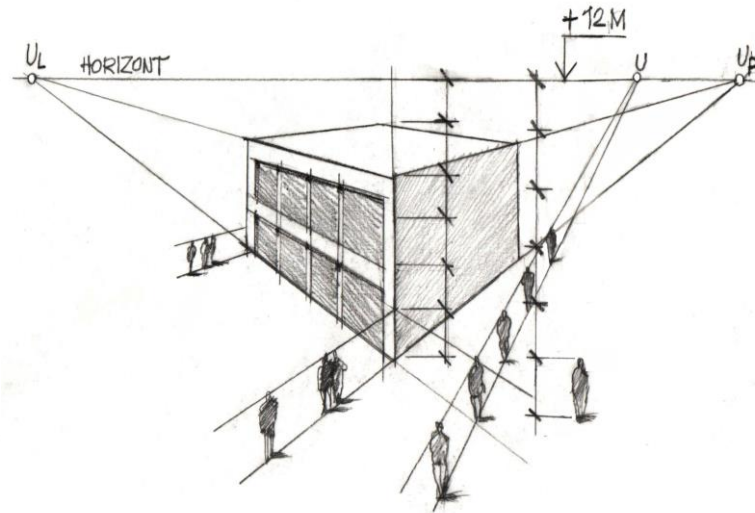
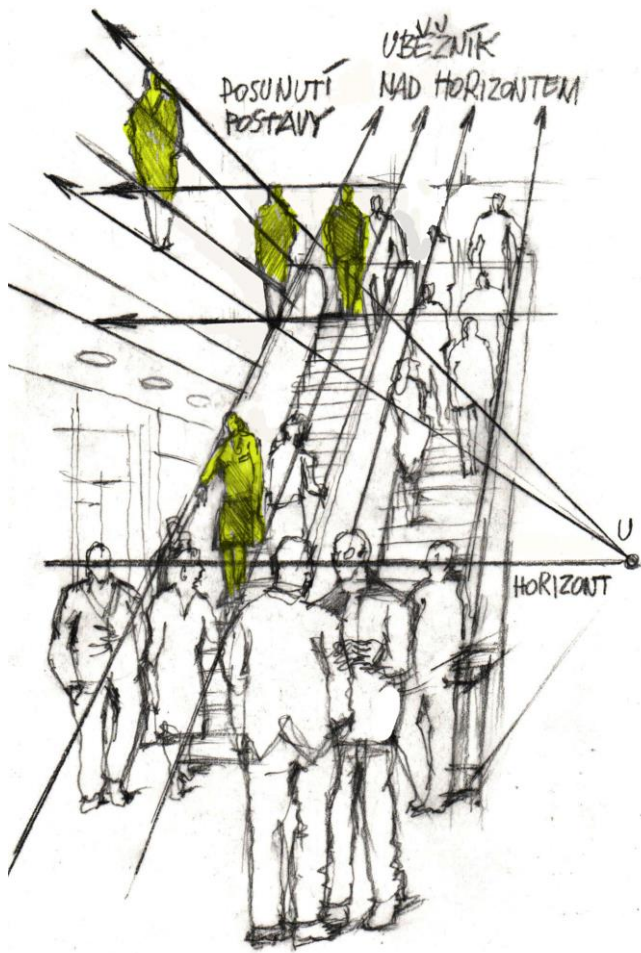

UMÍSTĚNÍ FIGURY DO PROSTORU NA RŮZNÉ ÚROVNĚ

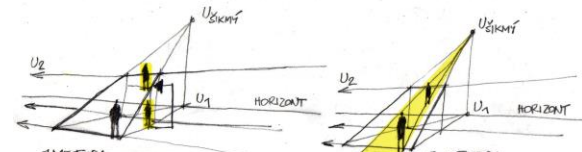

1. METODA
FIGURU NAKRESLÍM V
NORMÁLNÍM HORIZONTU
POD MÍSTEM, KDE JI CHCI
UMÍSTĚT
(MŮŽU SI JI JEN VEĚKOSTNĚ
VYZNAČIT)
PO TĚM JI ZVEDNU DO
POŽADOVANÉHO MÍSTA
(EVENTUÁLNĚ)

2. METODA
MŮŽU JI UŠEZNÍK
A FIGURU POSUNU
(V TOMTO PŘÍPADĚ
MŮŽU JI UŠEZNÍK)

ZDE UKÁŽU, KDY SE FIGURA
POSOUVÁ NA RŮZNÁ MÍSTA.
PŘÍBĚH SE POSOUVÁ 1. METODOU
(TJ. ZVEDÁNÍ ČI SNÍŽOVÁNÍ)
NEBO 2. METODOU (POSOUVÁNÍ
POMOCÍ UŠEZNÍKŮ)

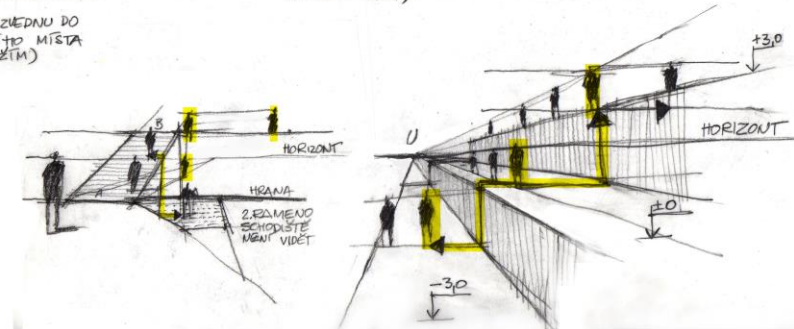

12. III.fáze: Užitečné doplňky: auta (manuál)

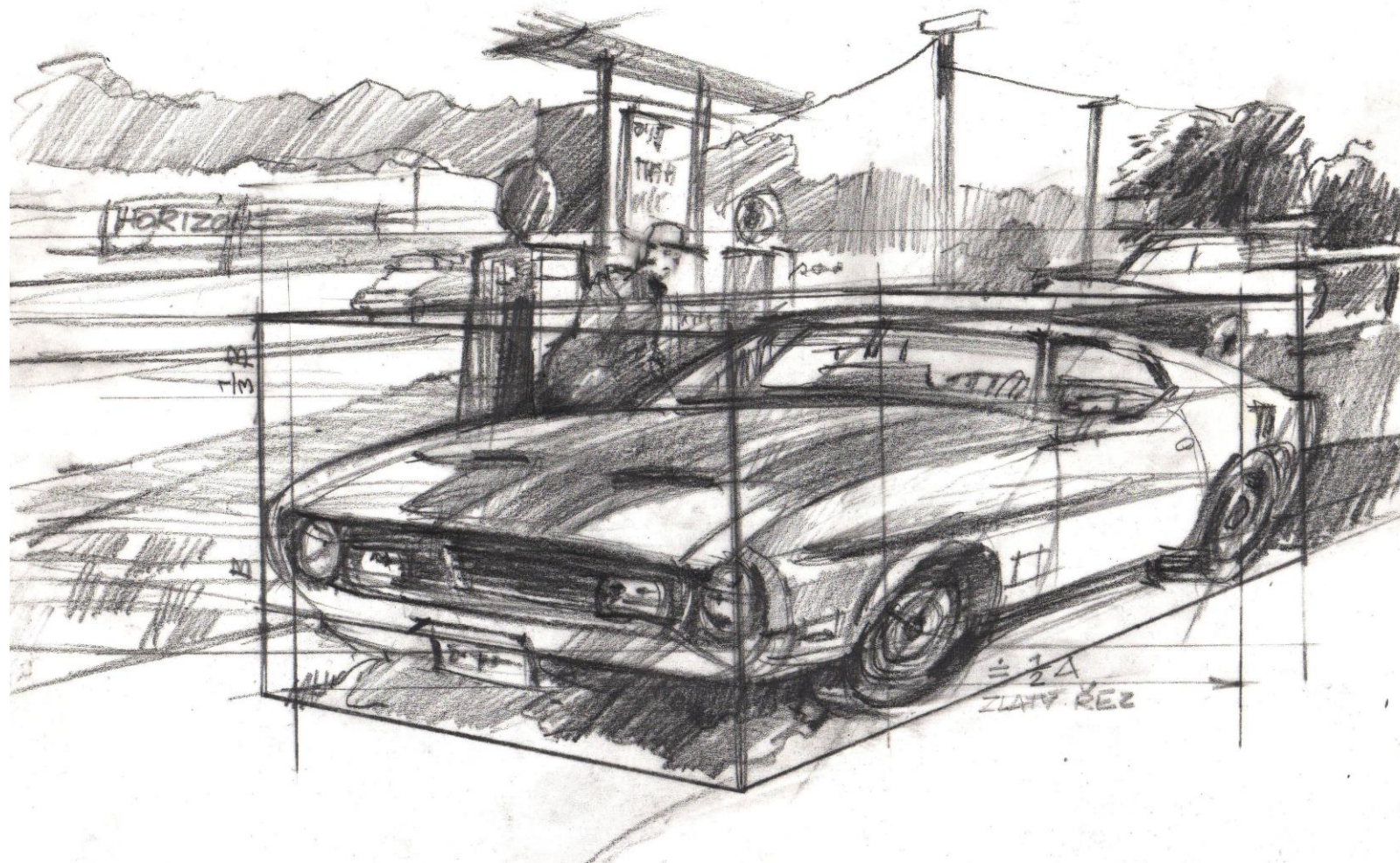
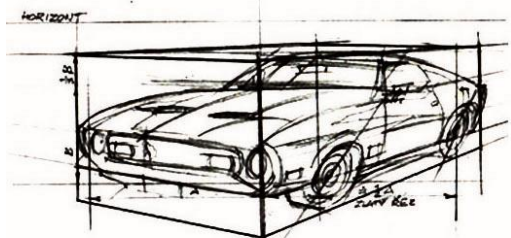
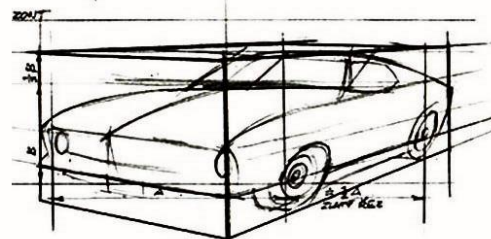
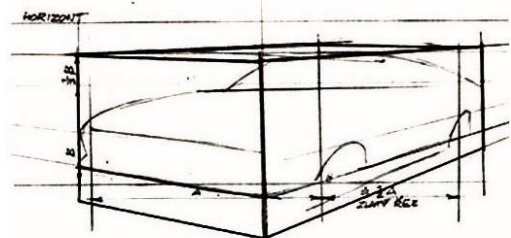
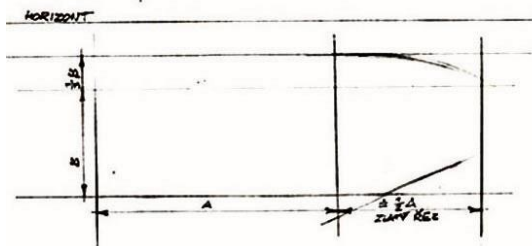

12. III.fáze: Užitečné doplňky: konstrukce stínů (respirium)

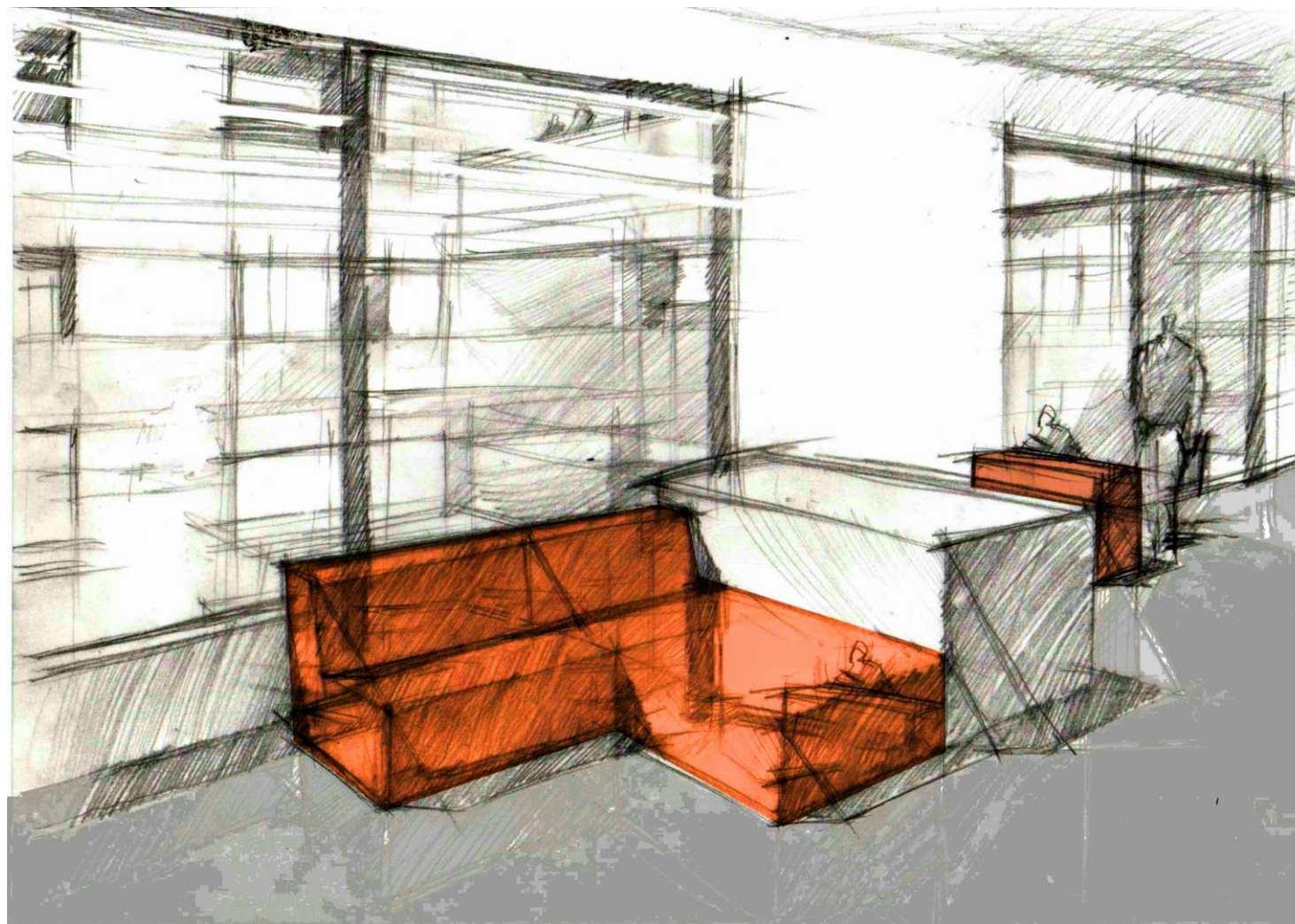
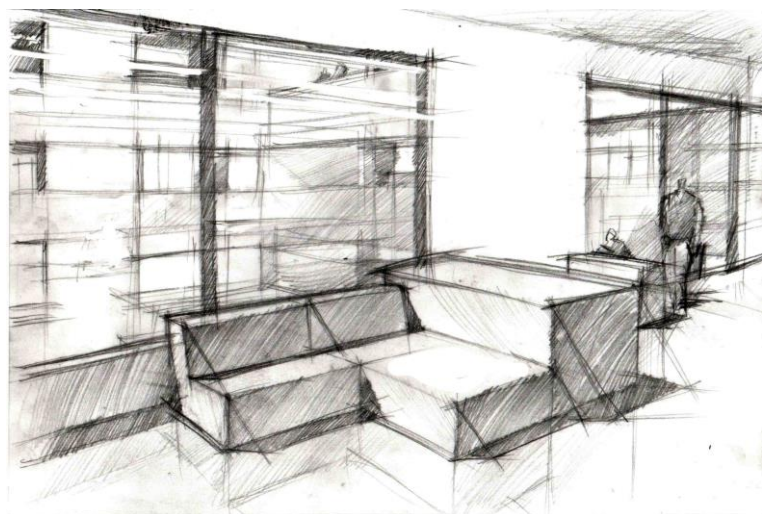

12. III.fáze: Užitečné doplňky: cvičení tři židle (konstrukce stínů)

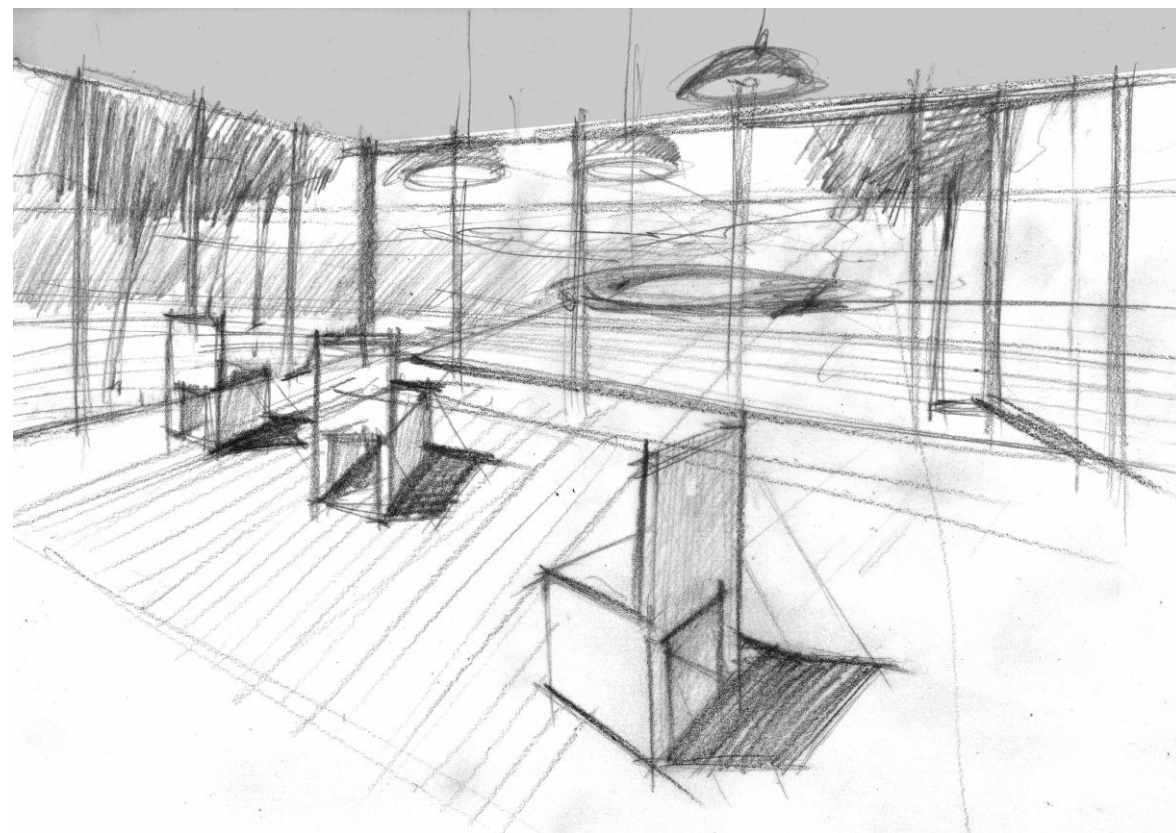
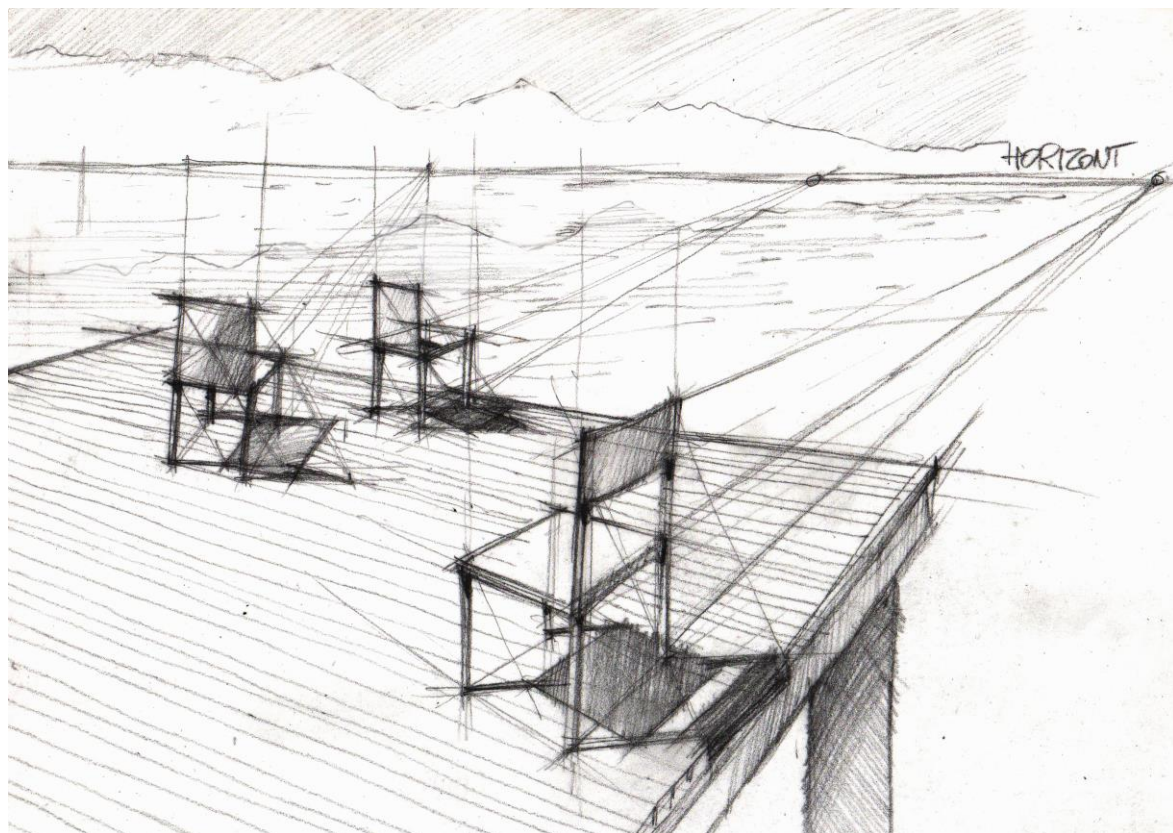

13. III.fáze: Cvičení: převádění předmětů do architektonických prostorů Axonometrie do perspektivy (náves)

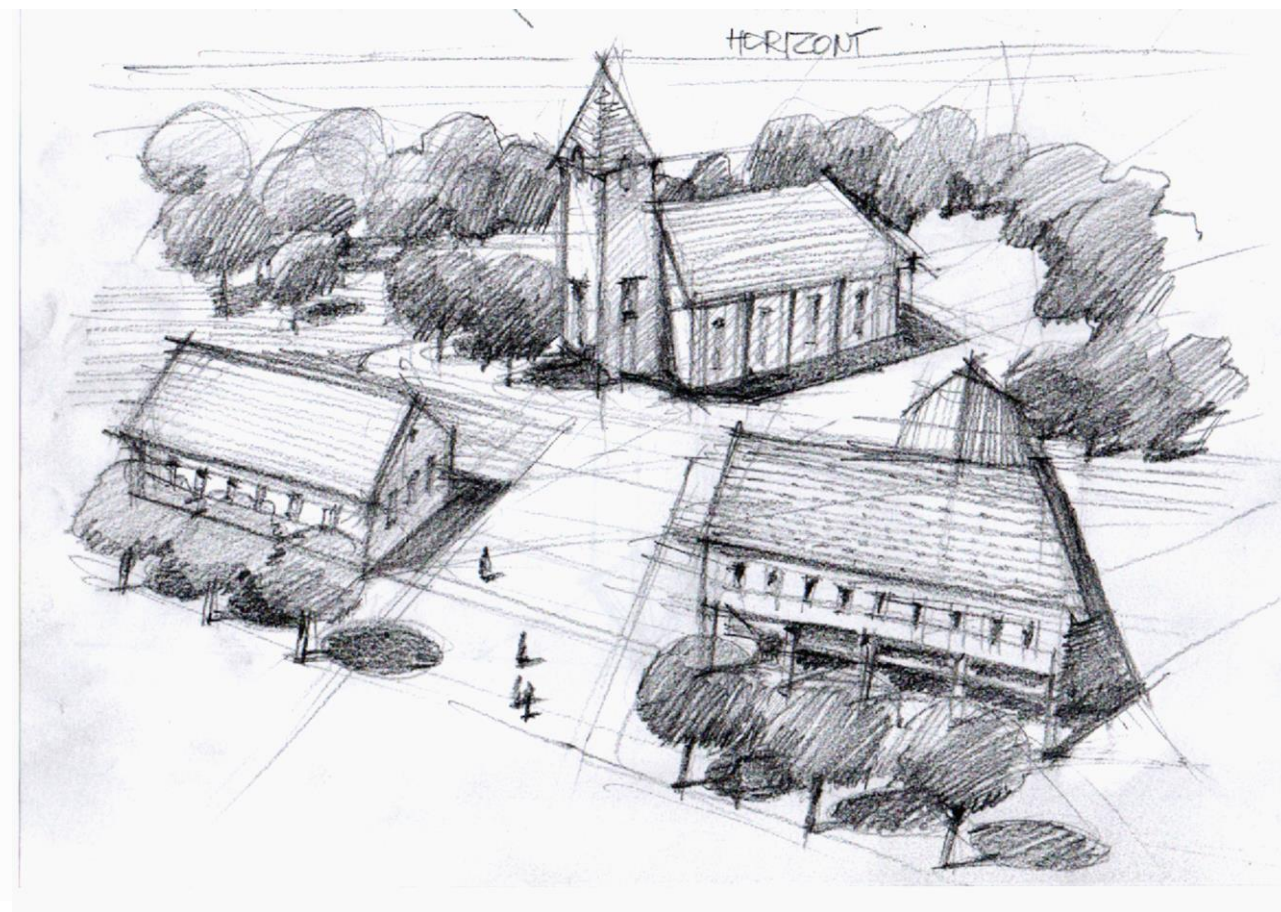
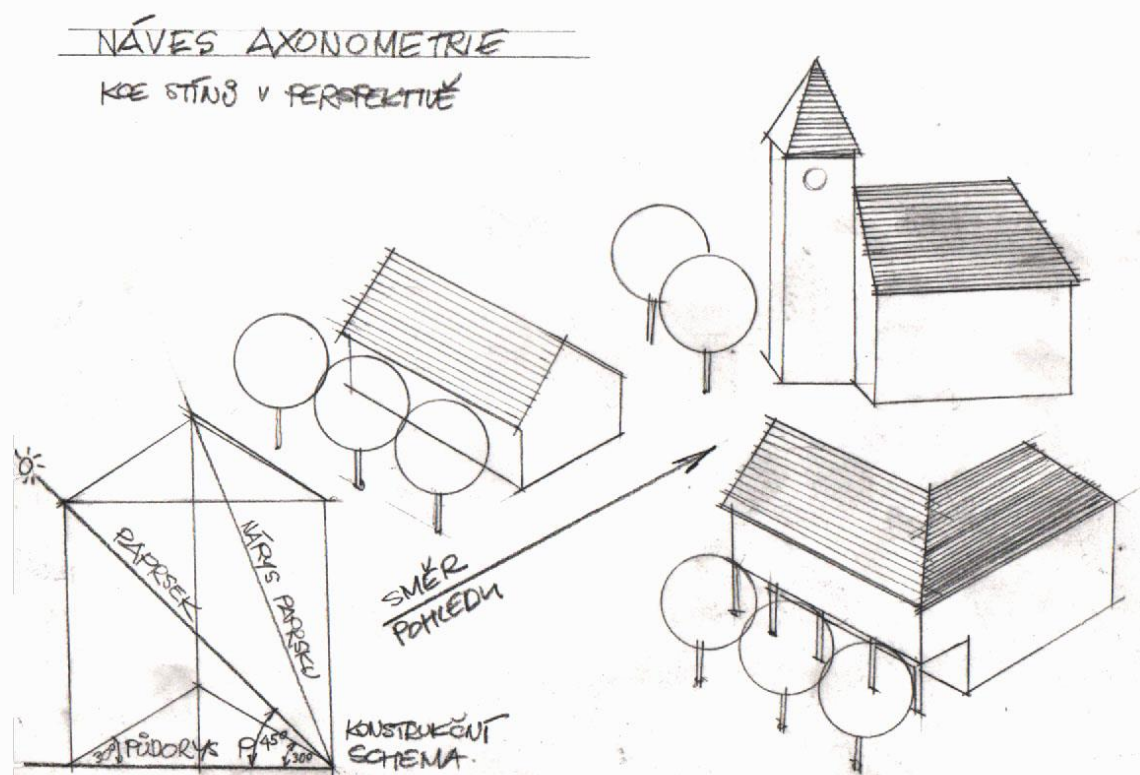

14. III.fáze: Cvičení: převádění předmětů do architektonických prostorů (např. zvětšováky, lampy, kanystry, disky)

